

SG-SD UNIT DIMENSIONS

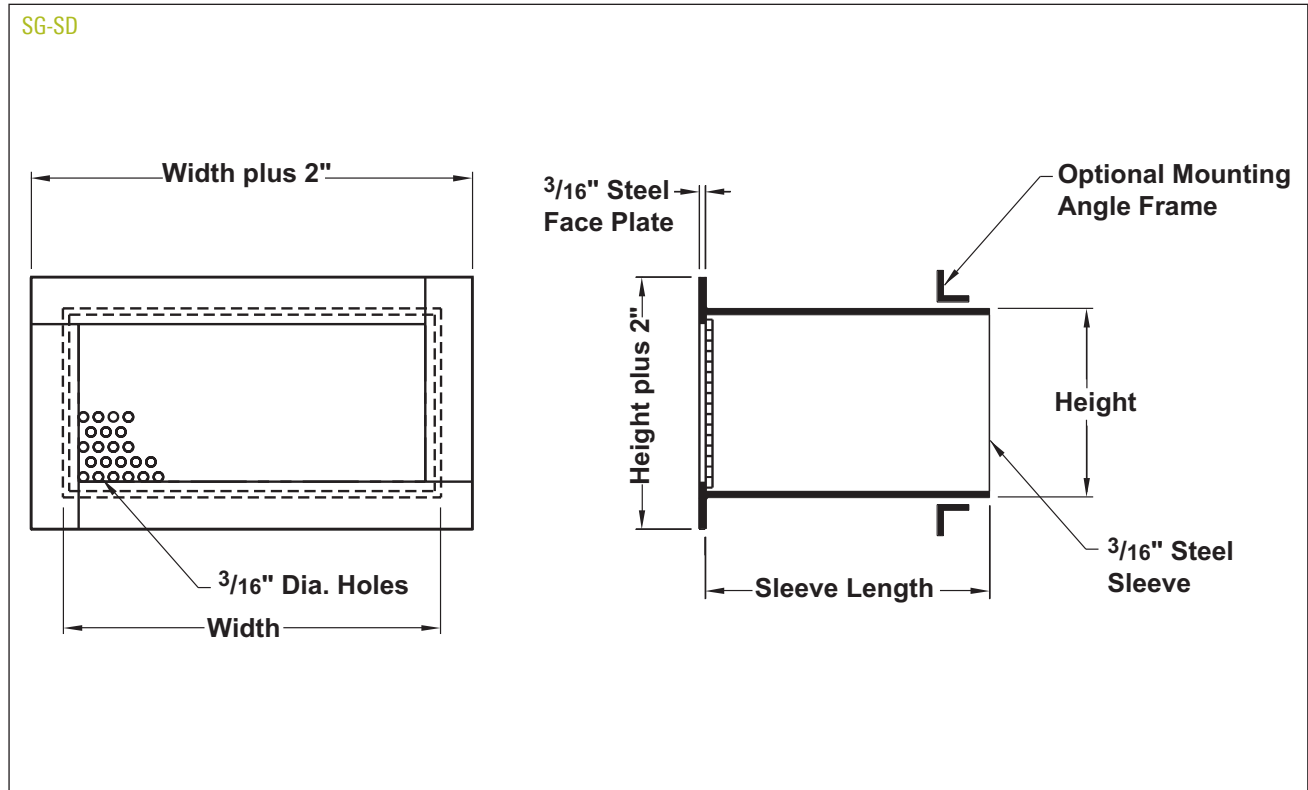

Notes:

For standard product, width and height should be specified in even 1" increments.

Typical mounting is accomplished by using an angle frame (1 1/2" x 1 1/2" x 3/16") shipped loose for field welding.

Dimensions Available	
Width:	6 to 30"
Height:	4 to 30"
Sleeve Length:	4 to 18" in 1" increments

Disclaimer:

The SG-SD is designed to increase inmate safety through compliance with the most recent known industry guidelines and design practices for products of its type. This is not meant to imply that the product cannot be used to inflict harm or is "suicide proof". Titus warrants only the construction and airflow performance of the product as cataloged.